

## **Water: The Fuel Cycle of the Future** (Alternative Fuel Source/Home Water Recycling System)

Sunlight is a form of renewable energy that is virtually limitless: more solar energy strikes the earth each hour than the entire world uses in a year! However, for solar energy to become practical, we need a cheap and efficient method of storing the solar energy for when the sun does not shine.

One method to achieve efficient storage of solar energy is in chemical bonds. Specifically, what scientists and engineers seek to do is use the energy from the sun to rearrange low energy bonds to form high energy bonds. The high energy bonds can be used later to deliver the energy back to us when we need it. This concept is comparable to when you charge a reusable battery. You get electricity from the wall socket, store it in the battery, and when you need to run your phone or computer, the energy is available.

One attractive approach for renewable energy storage is to use solar energy to drive the rearrangement of water (low-energy bonds) into molecular hydrogen gas and oxygen gas (high-energy bonds), as shown in the Equation below.

This transformation, often called water splitting, provides attractive alternatives to hydrocarbon fuels. The hydrogen and oxygen gas can be stored separately, and later brought together as fuel in what is called a fuel cell.

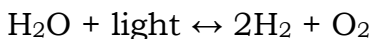

- $\text{H}_2\text{O}$  is water.
- $\text{H}_2$  is molecular hydrogen gas.
- $\text{O}_2$  is molecular oxygen gas

Hence, in this project the study of the water splitting as well as the understood of hydrogen fuel cells will be covered. The chemistry behind the chemical reaction to split the water as well as the fuel cells performance and operation will be studied.

### **Degree of Difficulty:**

Experimental: Moderated

Conceptual: Advanced

### **Objectives.**

- Examine water's usefulness as a renewable energy source (Alternative Fuel) by observing how efficient a sodium-based catalyst can be at helping to form molecular hydrogen.
- Study an alternative use of water (Water Recycling)
- Investigate how a fuel cell works and determine its efficiency.
- Power a device with the electricity generated from water.

**Materials:**

- 9V batteries (4)
- 22-gauge electrical wire
- Alligator clips (12)
- Wire cutters and strippers
- Breadboard, about 3" x 2"
- 10K Ohm resistor
- Voltmeter/Multimeter
- Cola; any brand, such as Coke, Pepsi, or a generic brand, will work
- Cup or jar that the nickel metal strips can completely fit inside (1); must be taller than 5 inches.
- 250 mL beaker
- Small Styrofoam block
- Nickel metal strips (2); strips should be approximately 5 inches tall and  $\frac{3}{4}$  inch wide.
- Ruler
- 0.1 M phosphate buffer solution, pH 7.0 (500ml)
  - This buffer should contain 2.63 g mono potassium phosphate ( $\text{KH}_2\text{PO}_4$ ) (FW 136.09 g/mol) and 4.35 g sodium phosphate ( $\text{Na}_2\text{HPO}_4$ ) (FW 141.96 g/mol) (to lower the pH to 7.0) and brought to 500 mL using deionized (DI) water for a total phosphate concentration of 0.1 M.
- Magnetic stir plate and stir bar. Most school chemistry labs have stir bars and stir plates. Try borrowing one from school or asking your teacher if you can run this experiment at school using this equipment.
- Pair of disposable gloves
- Metal scoop for chemicals
- Cobalt Nitrate (10 g)
- Clock or stopwatch
- Lab notebook
- Fuel Cell Technologies Fuel Cell Car Science Kit

**Procedure:**

- 1) Build a circuit on the breadboard consisting of the batteries, resistor, and voltmeter/multimeter.
- 2) Using the voltmeter/multimeter, make sure the circuit reads  $>30\text{V}$ .

- 3) Use the nickel metal strips as electrodes. The nickel electrodes will serve as the scaffold for formation or electroplating of the cobalt catalyst.
- 4) Add 0.1 M phosphate buffer solution, pH 7.0, to the beaker with electrodes so that the nickel electrodes are submerged half way in the buffer solution.
- 5) Place the stir bar in the bottom of the jar.
  - a) Make sure that the electrodes are not so low that the stir bar will bump them. If they are, raise them up until they are not.
- 6) Connect the nickel electrodes to the rest of the circuit using copper wire and alligator clips.

#### *Adding the Cobalt Catalyst and Measuring Its Effects*

- 1) With the electrodes securely in place inside the small beaker, place the beaker on the magnetic stir plate. Turn on the stir plate and get the stir bar moving at a constant rate.
  - a) Make sure that the stir bar does not bump the electrodes. Adjust the electrodes if needed, but then keep them in the same position throughout the rest of the experiment.
- 2) Monitor the voltage readout on the voltmeter/multimeter. It should range between 1.9-2.4v and will take at least five minutes to stabilize. After the voltage reading has stabilized, record this voltage in your lab notebook. This is the baseline voltage value for your electrochemical cell.
- 3) Now it is time to add the reactant necessary to form the cobalt-based catalyst. Put on a pair of disposable gloves and, using the metal scoop, add a pinch of the cobalt nitrate to the jar with the phosphate buffer and either start the stopwatch, or write down the time in your lab notebook. With the cobalt source and the energy provided by the batteries, the catalyst will start to form.
- 4) The cobalt-based catalyst will begin to electroplate onto the anodic (connected to + side of the battery) nickel electrode. As the catalyst film grows, you will see a brown film growing on the anode, and the voltage readout on the voltmeter/multimeter will slowly drop. Eventually, after several minutes, the voltage will settle to a stable reading. Record this voltage readout. Also record how long it took, using either the stopwatch or clock, to reach a stable voltage reading.
- 5) Once the voltage readout stabilizes, you can add more cobalt nitrate to the solution to initiate formation of more cobalt-based catalyst. Again, add only a small amount of cobalt nitrate at a time.
  - a) Record in your lab notebook how long it takes the voltage to stabilize again and what that final voltage reading is.

- 6) Repeat step 5 until the voltage does not appear to change with the addition of more cobalt nitrate. In this instance, the cobalt-based catalyst will continue to work, but no additional catalyst material will form.
- a) This may take a total of four or five additions of small amounts of cobalt nitrate, and with each addition it may take around 5 to 20 (or more) minutes for the voltage to stabilize.
- b) As you add more cobalt nitrate, how does the brown film on the anode change? Record any observations in your lab notebook.
- 7) Fill a second beaker with the same amount of phosphate buffer solution that you put in the first beaker.
- 8) Carefully remove the nickel electrodes from the phosphate buffer and put them into the second beaker that you just filled with fresh phosphate buffer.
- a) The beaker that the electrodes were in will still contain some unreacted cobalt nitrate, so the electrodes should be transferred to a beaker with fresh phosphate buffer.
- b) *Note:* Be careful not to jostle the electrodes when transferring them to the new beaker. It is important that they remain in the same position relative to each other and stay the same distance apart or it could give you inaccurate results.
- c) At this point you have finished forming the cobalt-based catalyst on the nickel electrodes. Measure and record the stabilized voltage one last time. The voltage readout in pure phosphate buffer reflects the operating potential of the electrochemical cell.

The system should be connected as shown in Figure 1.

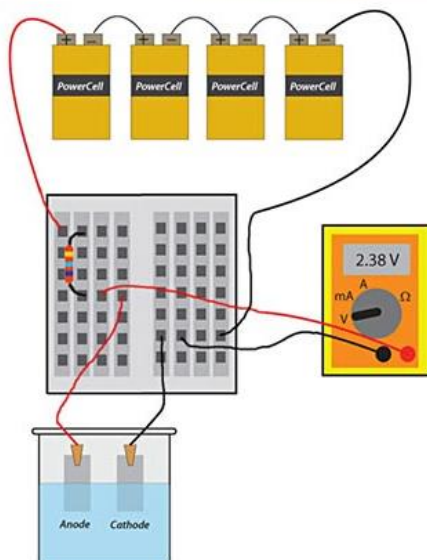

**Figure 1** schematic of the completed galvanostatic electrochemical cell

- 9) Clean up and disposal.
- The phosphate buffer solution can safely be disposed of down the drain.
  - The nickel electrodes can be saved with the cobalt-based catalyst still on them. Or, the nickel electrodes can be recovered and used again by rinsing them in cola

### **Activities:**

- 1) Analyze your data.
- Using Equation 1 and the information in Technical Note #2, calculate the final efficiency of the electrochemical cell with the cobalt-catalyst.

$$\% \text{ efficiency} = \left( \frac{\text{ideal voltage}}{\text{mesured voltage}} \right) \times 100\%$$

$$\% \text{ efficiency} = \left( \frac{1.23 \text{ V}}{\text{mesured voltage}} \right) \times 100\%$$

*Note: If the reaction were 100% efficient, it will require only 1.23 V to maintain the 3 mA of current passing through the cell. The voltmeter/multimeter would thus read 1.23 V*

- Compare the original efficiency of the cell calculated in step 3 to the final efficiency. How much does the cobalt-based catalyst increase the efficiency of the electrochemical cell?
- How quickly did the cobalt-catalyst form?
- Plot the *rate* of increase in efficiency for the number of times you repeated step 5. Was the rate of efficiency increase constant?

2) Use the principle of water splitting to power an electronic device.

3) Use alternatives source of energy to split the water that eventually will be used to power a hydrogen cell, use the generated power in a specific electronic device to prove the concept.

### **Final Project/Report**

Your have been asked to write a report how a hydrogen was produced starting from water, as well as obtaining of energy from alternative sources (solar). An operation manual for the connection of the solar cell

to split the water to the hydrogen cell all the way to power an electronic device. You have the freedom to make your own selections concerning the content of the manual. Do not forget to summarize all the experiments and the activities you have performed in this project.

In addition, have in mind the manual must be descriptive and understandable by people that have never hear about hydrogen cells, solar cells, and water splitting before. Therefore, sections about how to build the system (solar cell, water, hydrogen cell, and electronic device), how to use the system, and how/why the system works are strongly suggested to be included within your manual. Use of diagrams or pictures are strongly suggested. Have fun!

**References.**

1. <https://www.youtube.com/watch?v=Mt9tiJVtVLU>
2. [http://www.sciencebuddies.org/science-fair-projects/project\\_ideas/Energy\\_p002.shtml](http://www.sciencebuddies.org/science-fair-projects/project_ideas/Energy_p002.shtml)